



Prohibition on Sapinda Marriage

For Prelims: [Hindu Marriage Act, 1955 \(HMA\)](#), Prohibition on Sapinda Marriage, Crime of incest, Closely Blooded Relations.

For Mains: Prohibition on Sapinda Marriage, Government policies and interventions for development in various sectors and issues arising out of their design and implementation.

[Source: IE](#)

Why in News?

Recently, the Delhi High Court in the case of **Neetu Grover v. Union of India & Ors, 2024** has rejected a challenge to the constitutionality of **Section 5(v) of the [Hindu Marriage Act, 1955 \(HMA\)](#)**, which **prohibits marriage between two Hindus** if they are “Sapindas” of each other.

- A sapinda marriage involves **individuals who share a specific degree of familial closeness.**

Why Was the Law Challenged, and What Was the Court's Ruling?

▪ Arguments of Petitioner:

- In 2007, the petitioner's marriage was **declared void after her husband successfully proved** that they had **entered into a sapinda marriage**, and that the woman was not from a community where such marriages could be considered a custom.
- The petitioner challenged the constitutional validity of the **prohibition on sapinda marriages, arguing** that sapinda marriages are **prevalent even when there is no proof of custom.**
- Hence, **Section 5(v) which prohibits sapinda marriages** unless there is an established custom, violates the right to equality under Article 14 of the Constitution.
 - The petitioner also argued that if the marriage had received the consent of both families, **which proved the legitimacy of the marriage.**

▪ Delhi Court's Order:

- The Delhi High Court found no merit in her arguments, holding that the petitioner did not **provide “stringent proof” of an established custom**, which is necessary to justify a sapinda marriage.
- The court held that the choice of a partner in a marriage **can be subject to regulation.** With this in mind, the court held that the petitioner did not present any **“cogent legal ground”** to show that the prohibition against sapinda marriages was violative of the right to equality.

What is a Sapinda Marriage?

▪ About:

- A sapinda marriage is one **between individuals who are related to each other** within a **certain degree of closeness.**

- Sapinda marriages are defined under **Section 3 of the HMA**, as two persons are said to be “sapindas” of each other if one is a lineal ascendant of the other in the limits of sapinda relationship, or if they have a common lineal ascendant who is within the limits of sapinda relationship with reference to each of them.

▪ **Lineal Ascendant:**

- Under the provisions of the HMA, on the mother’s side, a Hindu individual cannot marry anyone **who is within three generations of them in the “line of ascent”**. On the father’s side, this prohibition applies to anyone within five generations of the individual.
- In practice, this means that on their mother’s side, an individual cannot marry **their sibling (first generation)**, their parents (second generation), their grandparents (third generation), or an individual who shares **this ancestry within three generations**.
- On their father’s side, this prohibition would extend up to their grandparents’ grandparents, and anyone who shares this ancestry within five generations.

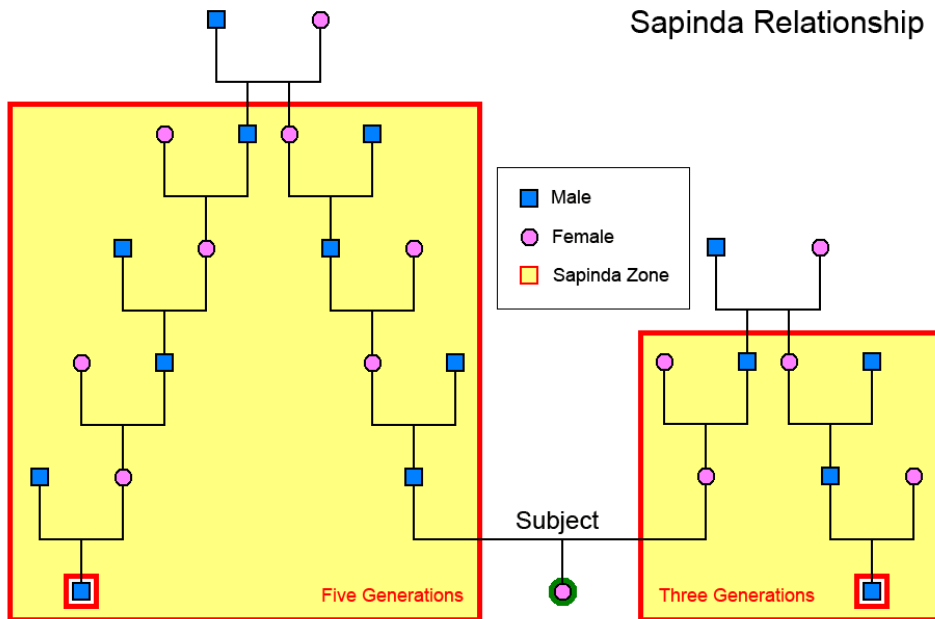

▪ **Section 5(v) of HMA 1955:**

- If a marriage is found to violate Section 5(v) for being a sapinda marriage, and there is no established custom that **allows such a practice, it will be declared void**.
- This would mean that the marriage was invalid from the very beginning, and will be treated as though it never took place.

Legal Provisions Related to Marriage

- The Constitution of India guarantees the [right to life and personal liberty under Article 21](#), which includes the **right to marry a person of one’s choice**.
- [The Special Marriage Act of 1954](#) allows any person to register and **solemnize their marriage with a person of their choice**.
- The **Supreme Court of India has dealt with several cases** involving the marriage of person of his/her choice. Like:
 - [Lata Singh v. State of U.P., 2006](#): The Court held that the right to marry a person of one’s choice is a fundamental right under Article 21, and that no one, including the parents or the community, can interfere with or object to such marriages.
 - [Shakti Vahini v. Union of India, 2018](#): [The Supreme Court](#) held that consensually choosing life partners is a manifestation of their freedom of choice guaranteed under [Articles 19 and 21 of the Constitution](#).

What are the Exceptions to the Prohibitions Against Sapinda Marriages?

- The exception is mentioned in Section 5(v) of the Hindu Marriage Act, 1955 and it states that **if the customs of the individuals involved permit sapinda marriages, then such marriages would not be declared void.**
- In other words, if there is an established custom within the community, tribe, group, or family that allows sapinda marriages, and if this custom is continuously and uniformly observed for a long time, it can be **considered a valid exception to the prohibition.**
 - The definition of "**custom**" is provided in **Section 3(a) of the HMA**, stating that a custom must be continuously and **uniformly observed for a long time and should have gained enough legitimacy among Hindus in a local area**, tribe, group, or family, such that it has obtained "the force of law."
- However, **certain conditions must be met for a custom to be considered valid.** The rule in question must be "certain and not unreasonable or opposed to public policy," and in the case of a rule applicable only to a family, it should not have been "discontinued by the family."
 - If these **conditions are satisfied**, and there is a valid custom permitting sapinda marriages, the marriage would **not be declared void under Section 5(v) of the HMA.**

Are Marriages Similar to Sapinda Marriages Allowed in Other Countries?

- **France and Belgium:**
 - In France and Belgium, the **crime of incest** was abolished under the **Penal Code of 1810**, allowing marriages between consenting adults.
 - Incest is the crime of sexual relations or marriage taking place between a male and female who are **closely linked by blood.**
 - Belgium maintained this legal stance even after introducing a new Penal Code in 1867.
- **Portugal:**
 - Portuguese law does not criminalise incest, implying that marriages between close relatives **may not be prohibited.**
- **Republic of Ireland:**
 - While the Republic of Ireland recognised same-sex marriages in 2015, the law on **incest has not been updated to explicitly** include individuals in same-sex relationships.
- **Italy:**
 - In Italy, incest is considered a crime only if it causes a "**public scandal**," suggesting that the legal framework takes into account certain circumstances.
- **United States:**
 - In the United States, incestuous marriages are generally banned in all 50 states. However, there are variations in laws related to incestuous relationships between consenting adults.
 - For example, New Jersey and Rhode Island **allow such relationships under certain conditions.**

Conclusion

- The concept of Sapinda marriages, as regulated by the HMA, reflects an effort **to preserve familial and social harmony** by prohibiting unions within certain lineal ascendants. The law includes provisions that declare marriages **void if they violate these restrictions unless there is a well-established custom** permitting such marriages.
- Internationally, various countries have different legal stances on incestuous relationships and marriages, showcasing the diversity of legal approaches to issues of personal choice and family relationships.

Legal Insight: [Prohibition on Marriage within Sapinda Relationships](https://www.drishtijudiciary.com/en)

<https://www.drishtijudiciary.com/en>

UPSC Civil Services Examination, Previous Year Question (PYQ)

Q. In the context of Indian history, the Rakhmabai case of 1884 revolved around (2020)

1. women's right to gain education
2. age of consent
3. restitution of conjugal rights

Select the correct answer using the code given below:

- (a) 1 and 2 only
(b) 2 and 3 only
(c) 1 and 3 only
(d) 1, 2 and 3

Ans: (b)

Exp:

- Rakhmabai (1864 - 1955) made her mark in history due to the legal case she was involved in, which contributed to the enactment of the Age of Consent Act, 1891.
- In 1885, after 12 years of marriage, her husband sought "restitution of conjugal rights", Rakhmabai was ordered to go live with her husband or spend six months in jail. Hence, 3 is correct.
- Rakhmabai refused to live with the man she was married to as a child, as she had no say in the marriage. Rakhmabai wrote to Queen Victoria. The Queen overruled the court's verdict and dissolved the marriage.
- The ripples that the case created led to the influence on the passage of the Age of Consent Act, 1891, which made child marriages illegal across the British Empire. Hence, 2 is correct.
- Though Rakhmabai became the first women doctor to practice medicine in British India, the case was not related to the women's right to gain education. Hence, 1 is not correct.
- Therefore, option B is the correct answer.